

INSTALLATION AND OPERATING INSTRUCTIONS

TO AVOID SERIOUS OR FATAL PERSONAL INJURY OR MAJOR PROPERTY DAMAGE, READ AND FOLLOW ALL SAFETY INSTRUCTIONS IN MANUAL AND ON PUMP.



Before installing and using the pump, read the following instructions carefully. The manufacturer declines all responsibility in case of accident or damage due to negligence or lack of observance of the instructions described in this booklet or in conditions that differ from those indicated on the nameplate; it also declines all responsibility for damage caused by improper use of the pump.

1. APPLICATIONS

- CEP BIG standard pumps are qualified to handle clean water or liquids similar to water in physical and chemical properties. The PH value of the transmission liquids shall be between 6.5 and 8.5.
- It is widely used for farm irrigation and drainage in factories, mines, schools, hospitals, hotels and cities. It can also be used as circulation pump for central air-conditioning and central heating system. With impeller of welding stainless steel or casting copper, it can be used as pumps for fire fighting system and spraying system.

2. MODEL DESCRIPTION

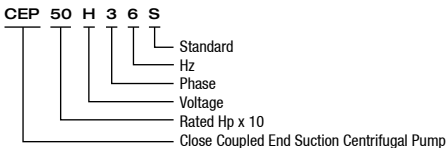

3. TECHNICAL DATA

Flow rate: 0 - 60 m³/h
 Head: 25 - 105 m
 Speed: 3500 rpm
 Insulation class: F
 Protection class: IP54(4-7.5kW), IP55(11-15kW)
 Max. operating pressure: 10 bar
 Max. ambient temperature: +40°C
 Max. liquid temperature: +75°C

4. IMPLEMENTATION STANDARDS

- 73/23/CEE
- 89/392/CEE
- 89/336/CEE
- Mechanical seal in compliance with DIN 24960
- Inlet and outlet DN in compliance with EN 733 and UNI 7467



5. SAFETY PRECAUTIONS

5.1. To ensure normal and safety operation of the electric pump, read manual carefully before use.

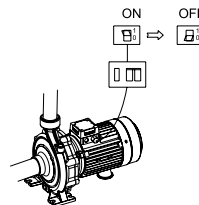
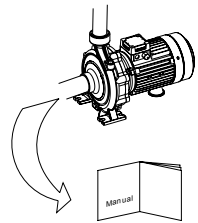

5.2. To avoid electric shock, make sure that the pump is safely grounded and equipped with an earth leakage circuit breaker. Do not get the plug wet and do not use any socket in an area with high humidity.

5.3. Do not touch the electric pump while working; do not wash or swim near the working area or let livestock into the water to avoid accident.

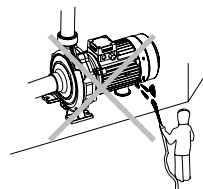
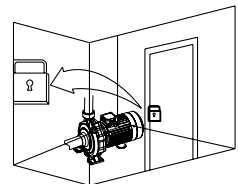

5.4. Avoid splashing pressurized water to the electric pump.

5.5. Make sure the pump is installed in a well-aired place.

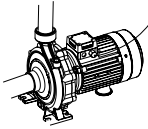
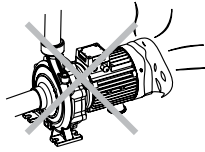

5.6. Before carrying out checks or doing any maintenance, clear the system by disconnecting the voltage, and then remove the pump plug from the socket.

5.7. Ensure the pump will not be accidentally turned on while installing and maintaining; if not used for a long time, cut off the power first and then turn off valves in inlet and outlet of the pump.

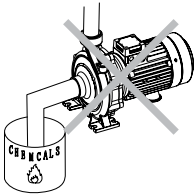
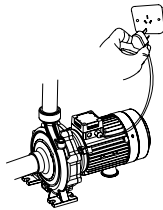

5.8. The pump must operate with clean water. It is not suitable for pumping inflammable, gasified or explosive liquids.

5.9. The power supply shall be in accordance with the voltage stated on the nameplate.

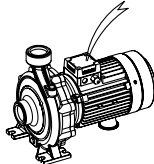

6. PRODUCT STRUCTURE

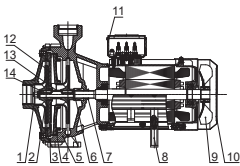

POS. PART

- 1 Pump cover
- 2 Impeller
- 3 O-sealing ring
- 4 O-sealing ring
- 5 Pump body
- 6 Mechanical seal
- 7 Water proof ring
- 8 Bracket
- 9 Fan

7. INSTALLATION

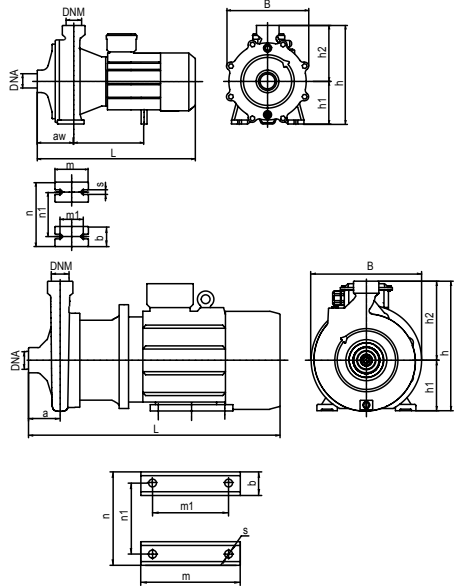

POS. PART

- 1 Pump body
- 2 Impeller
- 3 O-sealing ring
- 4 Motor connector
- 5 Motor
- 6 Terminal box
- 7 Coupling
- 8 Mechanical seal
- 9 Keys

MODEL	DNM	DNA	a	h2	w	x	b	c	h1	m	m1	n	n1	s	B	hmax	L
CEP 50	50	50	70	210	258	127	50	12	136	100	70	240	190	14	255	346	450
CEP 75			137	210	263	180	60	15	160	22	70	272	212	14	308	370	570
CEP 100			193	252	309	245	65	20	160	260	210	314	254	15	322	412	591
CEP 150			252	309	245	65	20	160	260	210	314	254	15	322	412	591	787
CEP 200			314	370	427	70	25	160	260	210	314	254	15	322	412	591	787

8. PERFORMANCE DATA

MODEL	speed (r/min)	Rated flow (m ³ /h)	Rated flow (m)	Power (kW)
CEP 50	3500	24	38	4
CEP 75		16	61	5.5
CEP 100		19	75	7.5
CEP 150		31	60	11
CEP 200		35	70	15

9. PRIOR TU USE

! During installation apply all the safety regulations issued by the competent authorities and dictated by common sense.

- 9.1. With the appropriate bolts secure the pump to flat and solid surfaces to avoid vibrations. The resistance of the motor shall be more than 50MΩ.
- 9.2. Before startup, check if the pump turns freely by rotating the fan. Remove the filling plug and fully fill the pump chamber with clean water, then tighten the filling plug.
- 9.3. In case the electric pump is far from the power supply, it's necessary to use a thicker cable. Otherwise the pump cannot work properly due to the big voltage drop.
- 9.4. Do not use soft rubber tube for inlet pipeline during installation. A foot valve shall be vertically installed with a distance of at least 30 cm from the water bottom to avoid suction of sediment.
- 9.5. Pay attention to the water level during operation. The foot valve shall not be above the water surface.
- 9.6. If the pump is not be used for a long time, it is advisable to empty it completely, wash it with clean water and store it in a dry, well-ventilated place.

! This product shall be installed and maintained by a qualified person who is proficient with this instruction. The installation and operation must be in accordance with local regulations and the recognized operation criteria. Install the pipeline properly according to the requirement of this instruction, and protect it from freezing.

CORRECT INSTALLATION
A DIAGRAM

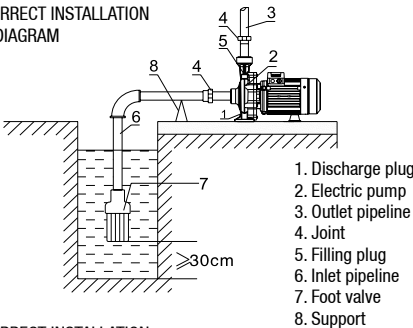

CORRECT INSTALLATION
B DIAGRAM

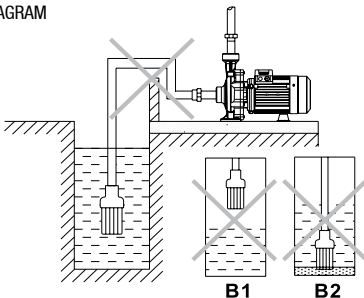

NOTES FOR INLET PIPELINE INSTALLATION:

- 1. Do not use too soft rubber tube for the inlet pipeline during pump installation.
- 2. The foot valve should be vertically installed 30cm from water bottom to avoid suction of sediment (A)
- 3. All connections of the inlet pipelines must be sealed. To ensure water suction, it's necessary to reduce the quantity of bents of the pipelines.
- 4. The diameter of the inlet pipe must not be less than that of the pump inlet to avoid big hydraulic loss and small water flow.
- 5. Pay attention to the water level during operation. The foot valve shall not be above the water surface (B).
- 6. In case the inlet pipe is longer than 10m in length or over 4m in hoisting height, the pipe diameter should exceed diameter of water inlet of the pump.
- 7. The pipelines should be anchored so that no stresses whatsoever is transmitted to the pump.
- 8. It is recommended to install a filter on inlet pipeline to avoid incoming of solid particles to the electric pump.

NOTE FOR OUTLET PIPELINE INSTALLATION:

The diameter of the outlet pipeline shall be not less than that of the pump outlet to reduce the pressure drop, high flow rate and noise to the lowest level.

10. ELECTRICAL CONNECTIONS



Make sure that there is no voltage at the line wire terminals before connecting. The electric pump shall be grounded reliably to avoid electric leakage and an earth leakage circuit breaker shall be equipped.

The electrical connection shall be carried out according to the local regulations. Check that the pump operates within the specified range on the nameplate. Connect up the pump (making sure that there is an efficient grounding circuit) according to the diagram on the nameplate on the motor. The correct direction of rotation for three-phase motors is clockwise, looking at the pump from the motor fan side. If this is not the case, invert two of the phases.

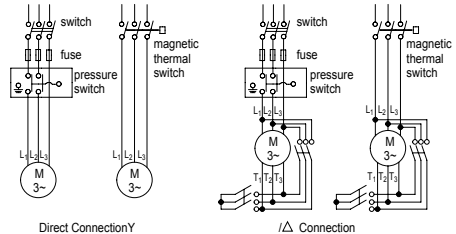

DIRECT CONNECTION Y

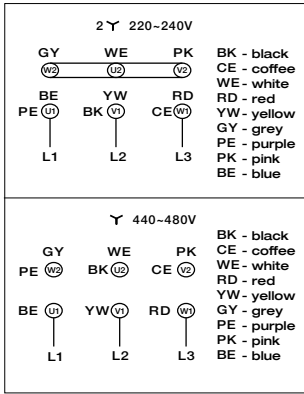

△ CONNECTION

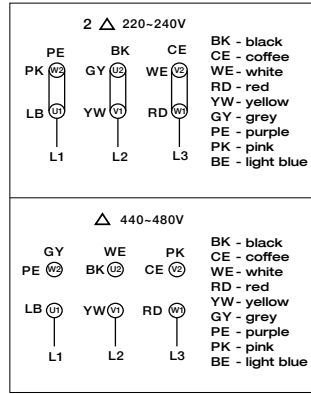

11. STARTUP AND MAINTENANCE

! Do not operate the pump unless the pump chamber is fully filled with clean water. Dry operation of the pump will cause damage to the mechanical seal. Do not touch the electric pump unless the power of pump is cut off for over 5 minutes. Do not remove the pump bonnet unless the water in pump chamber is completely drained.

Keep the valve narrow opened during startup. When the pump runs normally, adjust the valve to the required flow. When not using the pump and the ambient temperature is below 4, empty the pump completely for frost and freeze protection. The priming procedure must be repeated to restart the pump.

Rotate the fan with a screwdriver to check if the pump rotates flexibly before startup. Remove the filling plug and prime the pump chamber fully with clean water, then tighten the filling plug.

! Attention! If the appliance or the supply cord is damaged, it must be repaired by manufacturer, its service agent or qualified person.

12. TROUBLESHOOTING

PROBLEM	POSSIBLE CAUSE	REMEDY
The pump does not start	Low voltage	Regulate voltage variation between +/-10%
	Impeller blocked	Clean the impeller by removing it
	Cable broke or one phase disconnected	Check out outlet box and replace the cable
	Stator winding burnout	Replace the stator winding
Insufficient liquids pumped	Excessive head	Choose appropriate standard pump according to the scope of application
	Foot valve clogged or filter screen blocked	Clean up the float grass
	Suction pipe leakage	Tighten the adaptor of suction pipe evenly
	Mechanical seal damage	Replace mechanical seal
Stator winding burnout	Wrong grounded circuit or phase failure of power	Fix the problems by removing the winding, re-embedding, the winding, re-embedding, drying it by heat.
	Seal box broken and the coil burns out	
	Long time of dry operation	
	Impeller blocked or long-time running	
	Cable broke and winding exposed to moisture	



3000 W. 16 Ave. Miami, FL 33012

Tel: (954) 4749090 | Fax: (954) 8890413

info@pearlwatersystems.com | www.pearlwatersystems.com